

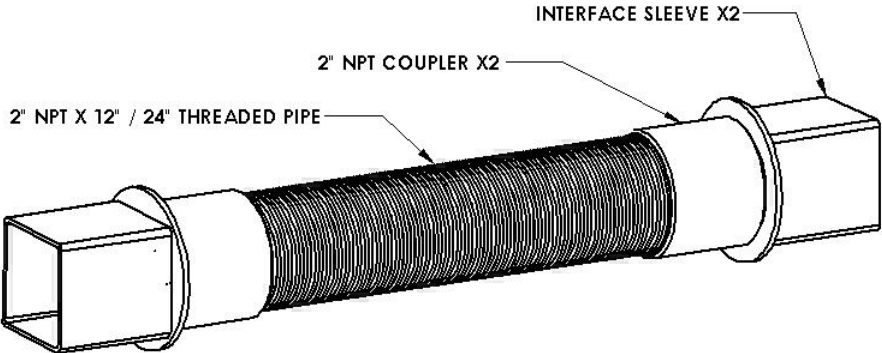

Product Code SDS-TW-004-12 SDS-TW-004-24	Nominal Dimensions 2" x 12" 2" x 24"				
Description <p>This Through-Wall Kit provides a 2" through-wall pathway from one Secure Raceway section to another Secure Raceway section.</p>					
Specifications <table border="0" style="width: 100%;"> <tr> <td style="width: 50%; vertical-align: top;"> 12" <ul style="list-style-type: none"> Galvanized steel threaded pipe Total weight: 5.1 lbs </td> <td style="width: 50%; vertical-align: top;"> 24" <ul style="list-style-type: none"> Galvanized steel threaded pipe Total weight: 7.6 lbs </td> </tr> <tr> <td style="vertical-align: top;"> Through-Wall Kit includes: <ul style="list-style-type: none"> One (1) - 2" x 12" NPT threaded pipe Two (2) – 2" NPT couplers Two (2) Interface Sleeves </td> <td style="vertical-align: top;"> Through-Wall Kit includes: <ul style="list-style-type: none"> One (1) - 2" x 24" NPT threaded pipe Two (2) – 2" NPT couplers Two (2) Interface Sleeves </td> </tr> </table>			12" <ul style="list-style-type: none"> Galvanized steel threaded pipe Total weight: 5.1 lbs 	24" <ul style="list-style-type: none"> Galvanized steel threaded pipe Total weight: 7.6 lbs 	Through-Wall Kit includes: <ul style="list-style-type: none"> One (1) - 2" x 12" NPT threaded pipe Two (2) – 2" NPT couplers Two (2) Interface Sleeves
12" <ul style="list-style-type: none"> Galvanized steel threaded pipe Total weight: 5.1 lbs 	24" <ul style="list-style-type: none"> Galvanized steel threaded pipe Total weight: 7.6 lbs 				
Through-Wall Kit includes: <ul style="list-style-type: none"> One (1) - 2" x 12" NPT threaded pipe Two (2) – 2" NPT couplers Two (2) Interface Sleeves 	Through-Wall Kit includes: <ul style="list-style-type: none"> One (1) - 2" x 24" NPT threaded pipe Two (2) – 2" NPT couplers Two (2) Interface Sleeves 				

	HOLOCOM, INC. customerservice@holocom.com www.holocom.com	PRODUCT CODE: SDS-TW-004-12 / SDS-TW-004-24	TITLE: THROUGH-WALL KIT
		All material contained in this document is the property of Holocom, Inc. and may not be reproduced or transmitted (including electronically) without the written consent of Holocom, Inc. Holocom and the Holocom logo are registered trademarks of Holocom, Inc. Other noted marks are trademarks of their respective companies. Holocom products protected by US Pats. 7,183,488; 7,115,814; 7,053,303; 7,049,517; 6,838,616; 5,831,211 and Pats. pending. Made in the U.S.A. Copyright © 2008 Holocom, Inc. All rights reserved.	