

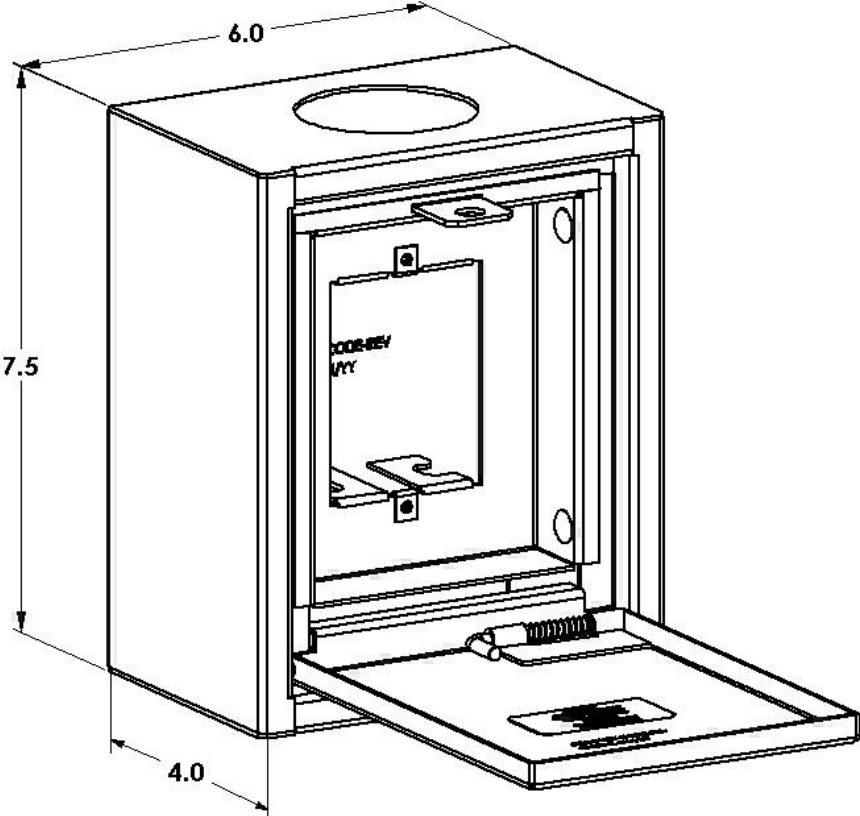

<b>Product Code</b>  <b>SEC-WM-UDB-H1</b>	<b>Dimensions</b>  7.5" x 6" x 4"	
<b>Description</b>  The 16-gauge High Security User Drop Box (UDB) provides physical security for single or multiple network connections. The UDB mounts securely on walls and restricts access to the cable termination point. Built-in back plate and cable manager, manufactured mounting points, and INF-ready top opening reduce installation time. Within the protective distribution system, the UDB can also be used as a small pull box. The door locks securely using Holocom's patented locking system and a Sargent & Greenleaf® padlock.		
<b>Specifications</b>  <b>Enclosure</b> <ul style="list-style-type: none"> <li>• Height 7.5" x Width 6" x Depth 4"</li> <li>• 16-gauge electro-galvanized steel</li> <li>• Weight 4.0 lbs</li> <li>• 2 3/8" diameter opening - ready for INF and raceway attachment</li> <li>• Two labor-saving, manufactured mounting points</li> </ul> <b>Door Assembly</b> <ul style="list-style-type: none"> <li>• Single drop-down door with security padlock hasp</li> <li>• Tamper resistant design with welded internal spring hinge</li> </ul> <b>Back Plate</b> <ul style="list-style-type: none"> <li>• Integrated tension relief cable management wrap</li> <li>• Removable</li> </ul> <b>Accessories</b> <ul style="list-style-type: none"> <li>• Sargent &amp; Greenleaf® padlock (supplied separately)</li> </ul> <b>Powder Coat Finish: White Textured</b>  <sup>1</sup> Compatible with most US single-gang faceplates. Angled connectors recommended.		

	HOLOCOM, INC. <a href="mailto:customerservice@holocom.com">customerservice@holocom.com</a> <a href="http://www.holocom.com">www.holocom.com</a>	<b>PRODUCT CODE:</b>  <b>SEC-WM-UDB-H1</b>	<b>TITLE:</b>  USER DROP BOX (UDB)
All material contained in this document is the property of Holocom, Inc. and may not be reproduced or transmitted (including electronically) without the written consent of Holocom, Inc. Holocom and the Holocom logo are registered trademarks of Holocom, Inc. Other noted marks are trademarks of their respective companies. Holocom products protected by US Pats. 7,183,488; 7,115,814; 7,053,303; 7,049,517; 6,838,616; 5,831,211 and Pats. pending. Made in the U.S.A. Copyright © 2008 Holocom, Inc. All rights reserved.			