

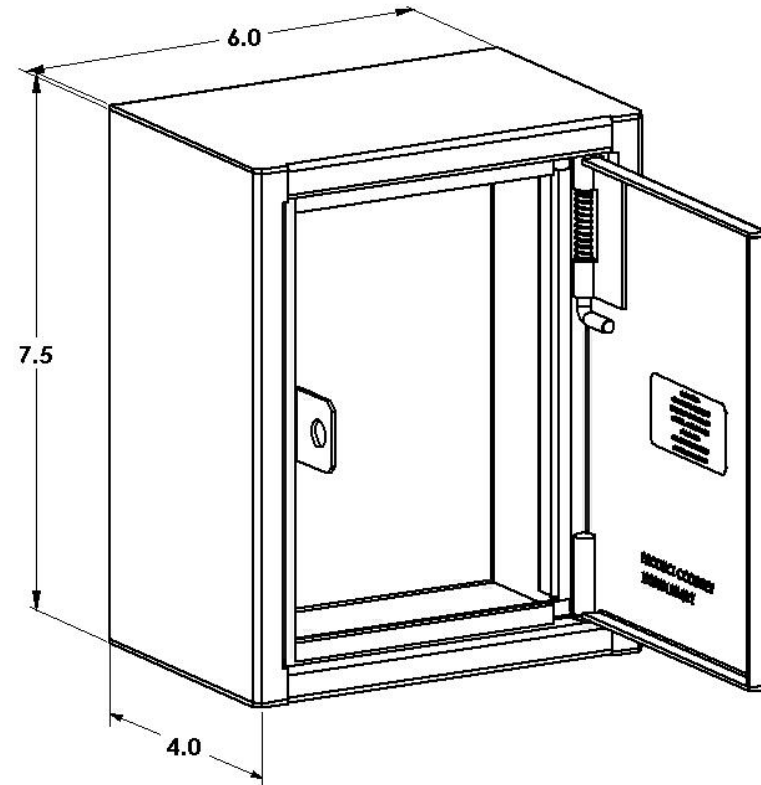

Product Code SEC-WM-764-H1	Nominal Dimensions 7.5" x 6" x 4"	
Description This 16-gauge High Security Enclosure can be mounted on walls or desktops and provides physical security for surface mount boxes or any other connection point. The Retrofit Insert—Back Plate (SDS-IN-RTF) may be used in conjunction with this enclosure thereby eliminating the need to order and install surface mount boxes. The Retrofit Insert also reduces installation time and provides a cleaner look inside the enclosure. The door securely locks using Holocom's patented locking system and the Sargent and Greenleaf® padlock.		
Specifications <ul style="list-style-type: none"> • Height 7.5" x Width 6" x Depth 4" • 16-gauge electro-galvanized steel • Weight: 4 lbs • Single door with security padlock hasp • Tamper-resistant design with welded internal hinges • Fits with Retrofit Insert—Back Plate (SDS-IN-RTF) <p>Powder Coat Finish: White Textured</p>		

	HOLOCOM, INC. customerservice@holocom.com www.holocom.com	PRODUCT CODE: SEC-WM-764-H1	TITLE: HIGH SECURITY ENCLOSURE
All material contained in this document is the property of Holocom, Inc. and may not be reproduced or transmitted (including electronically) without the written consent of Holocom, Inc. Holocom and the Holocom logo are registered trademarks of Holocom, Inc. Other noted marks are trademarks of their respective companies. Holocom products protected by US Pats. 7,183,488; 7,115,814; 7,053,303; 7,049,517; 6,838,616; 5,831,211 and Pats. pending. Made in the U.S.A. Copyright © 2008 Holocom, Inc. All rights reserved.			