

Product Code	Nominal Dimensions
SEC-WM-PB8-H1	24" x 24" x 10"

Description

This High Security Pull Box enclosure mounts securely to walls and was designed to protect classified cabling within the Holocom PDS system as an access point, or as a traditional pull box in non-Holocom systems. Additionally, there are vertical mounting rails welded to the back of the enclosure. They can be used with the included set of 4U equipment brackets to mount equipment vertically. The door securely locks using a 3-point lock system and Holocom's patented door back flange, as well as the Sargent and Greenleaf® padlock.

- Specifications**
- Height 24" x Width 24" x Depth 10"
 - 16-gauge electro-galvanized steel with welded seams
 - Weight: 47 lbs
 - Tapped vertical mounting rails welded to the back of the enclosure for mounting included 4U equipment brackets or other network gear
 - MBK-EQ-04U-01 equipment brackets included. May be replaced with the MBK-PP-04U-01 Patch Panel Bracket (Sold separately)
 - Single door with 3-point security and padlock hasp
 - Tamper-resistant design with welded internal hinges
- Powder Coat Finish: White Textured

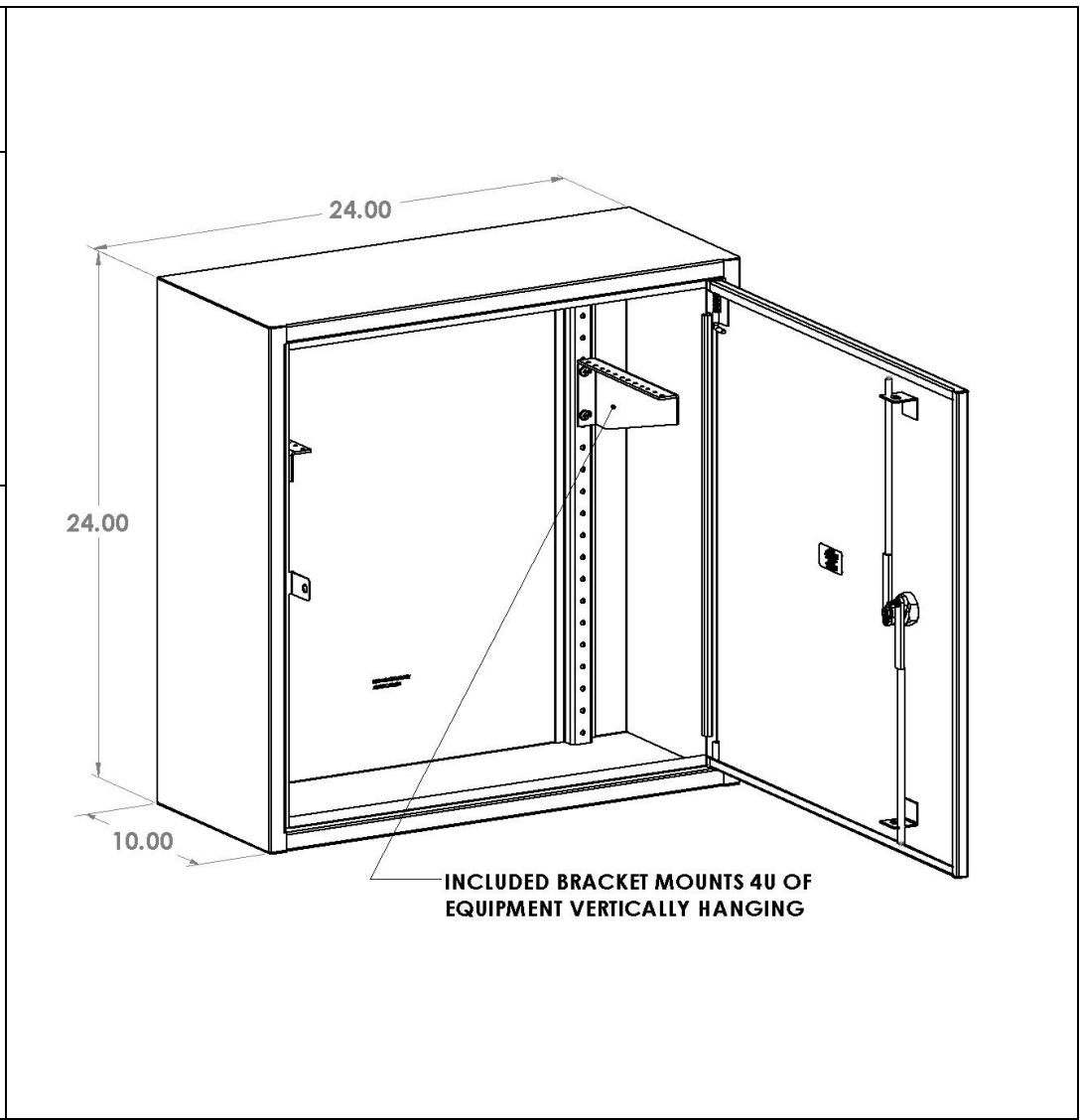

HOLOCOM, INC.
customerservice@holocom.com
www.holocom.com

PRODUCT CODE:
SEC-WM-PB8-H1

TITLE:
 HIGH SECURITY PULL BOX

All material contained in this document is the property of Holocom, Inc. and may not be reproduced or transmitted (including electronically) without the written consent of Holocom, Inc. Holocom and the Holocom logo are registered trademarks of Holocom, Inc. Other noted marks are trademarks of their respective companies. Holocom products protected by US Pats. 8,733,798; 7,661,375; 7,608,780; 7,183,488; 7,115,814; 7,053,303; 7,049,517; 6,838,616; 5,831,211; 632,763; 619,097; 580,871 and patents pending.
 Made in the U.S.A. Copyright © 2015 Holocom, Inc. All rights reserved.