

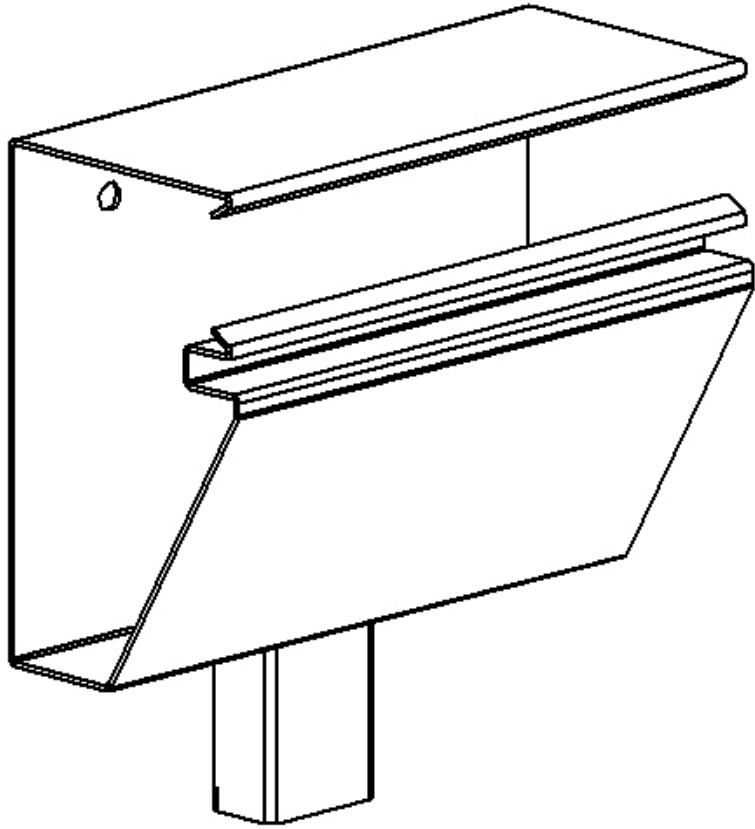

<b>Product Code</b>  <b>SLC-SMD-DP</b>	<b>Nominal Dimensions</b>  N/A	
<b>Description</b>  The Secure Large Carrier™ to Secure Mini Dukt™ Drop Connector provides the transition between Secure Large Carrier™ Raceway and Secure Mini Dukt™, usually leading to a User Drop Box. Installation requires two (2) Mounting Brackets (SLC-WM-MB) and two (2) Secure Raceway Joints (SLC-RW-SRJ) and TopCap from the SLC Raceway Kit (SLC-WM-RCW-ST-20). Two (2) manufactured mounting points align with the Mounting Brackets allowing simplified, labor-saving installation and a one-inch standoff.		
<b>Specifications</b> <ul style="list-style-type: none"> <li>• 16-gauge electro-galvanized steel on SLC component</li> <li>• 18-gauge electro-galvanized steel on SMD component</li> <li>• Two (2) manufactured mounting points 1.5" from each end</li> <li>• Weight 2.5 lbs</li> </ul> Powder Coat Finish: White Textured		

	Holocom, Inc. <a href="http://www.holocom.com">www.holocom.com</a>	<b>PRODUCT CODE:</b> <b>SLC-SMD-DP</b>	<b>TITLE:</b> <b>SECURE LARGE CARRIER™ SMD DROP CONNECTOR</b>
All material contained in this document is the property of Holocom, Inc. and may not be reproduced or transmitted (including electronically) without the written consent of Holocom, Inc. Holocom and the Holocom logo are registered trademarks of Holocom, Inc. Other noted marks are trademarks of their respective companies. Holocom products protected by US Pats. 7,183,488; 7,115,814; 7,053,303; 7,049,517; 6,838,616; 5,831,211; 7,608,780; D580,871; 7,661,375; D632,763; D619,097 and patents pending. Made in the U.S.A. Copyright © 2012 Holocom, Inc. All rights reserved.			